

# HEADLAMP AIMING CHART

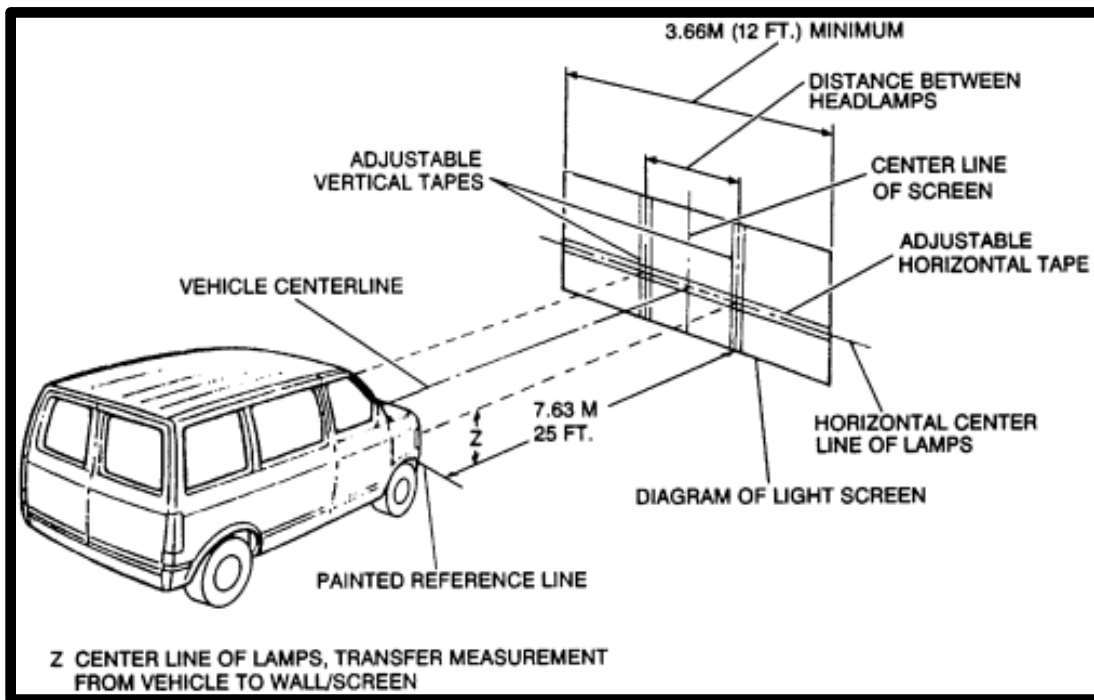

**Headlamp Aiming Criteria:** at the correct distance (25'), a reject would occur if the brightest portion of the beam is more than 4" to the right or more than 4" to the left of the vertical center line or more than 4" above or more than 4" below the horizontal center line. Remember, the vehicle must be positioned properly on a flat and level surface in front of a wall.



## Note: Establishing Horizontal and Vertical Center Lines:

1. On a flat and level surface, pull the vehicle as close to a wall as possible and turn on the lights (low beam). Find the centers of the projected beams. Mark both spots horizontally, with a single piece of tape which runs through the middle of the projected beams. Now, mark both spots with vertical tape markers, about two feet in length, running through the center of each projected beam.
2. Back the vehicle up until it is 25 feet from the wall. Look at where each beam's "hot spot" falls compared to the markings you made. For vertical aim, the top of the most intense part of the beam should be at or below the horizontal tapeline.
3. Follow the criteria above for pass or reject outcomes.
4. This criteria does not apply if utilizing a **Mechanical Headlight Aiming Device**.